

MATH 123
Visualization

Day 6

Did Caravaggio Use a Camera?

Richard Hammack

<http://www.people.vcu.edu/~rhammack/Math123/>

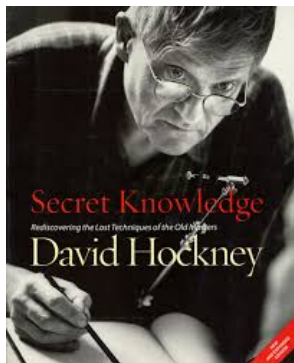

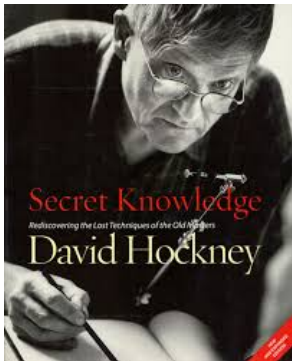

Outline of talk:

1. Perspective in the Renaissance
2. Optics of curved mirrors
3. Hockney's theories



Spanish, c. 1180



Lippo Memmi (Italian, Sienese) c. 1340

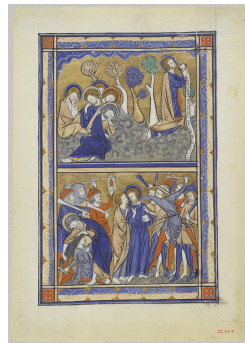

English, c. 1270

Giotto di Bondone

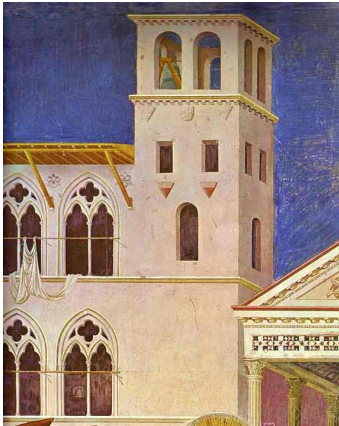

Homage of a Simple Man

(detail) 1295–1300



Meeting at the Golden Gate

1304–1306

Giotto di Bondone



Homage of a Simple Man

(detail) 1295–1300



Meeting at the Golden Gate

1304–1306



Duccio di Buoninsegna, c. 1310



Duccio di Buoninsegna, c. 1310



Duccio di Buoninsegna, c. 1310

Fra Angelico



Annunciation, c. 1450

Fra Angelico



Annunciation, c. 1450



Sandro Botticelli, *Annunciation*, c. 1490



Sandro Botticelli, *Annunciation*, c. 1490

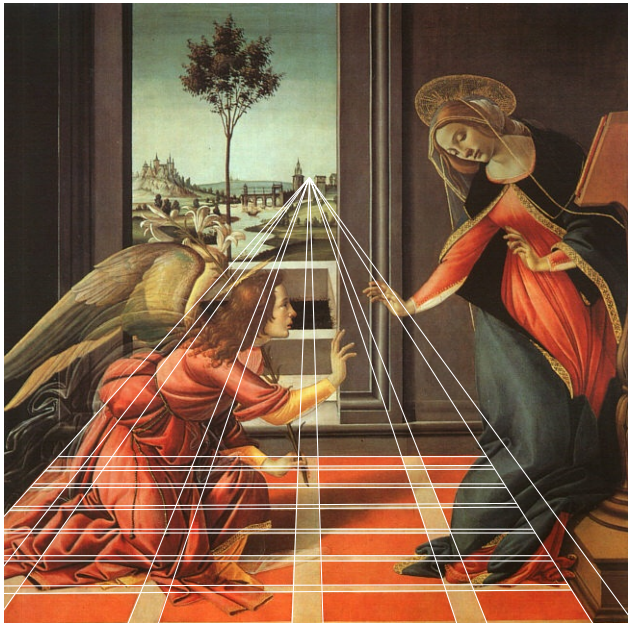

Sandro Botticelli, *Annunciation*, c. 1490

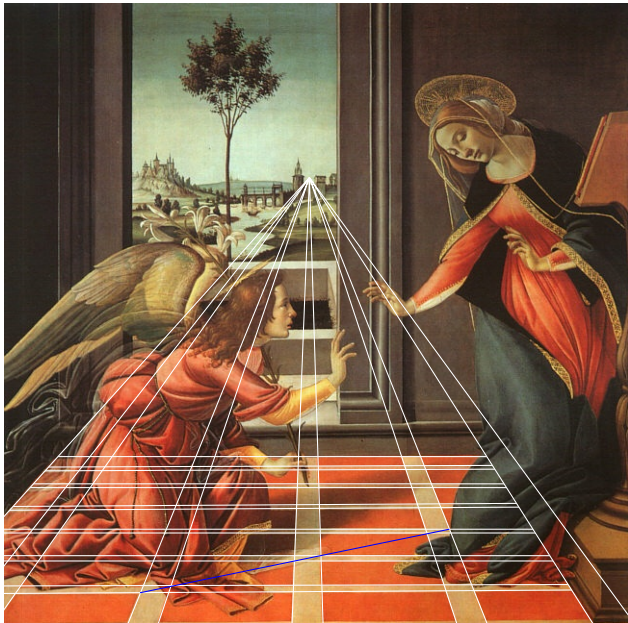

Sandro Botticelli, *Annunciation*, c. 1490



Piero della Francesca (1415–1492)

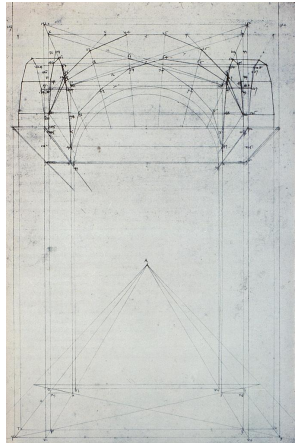
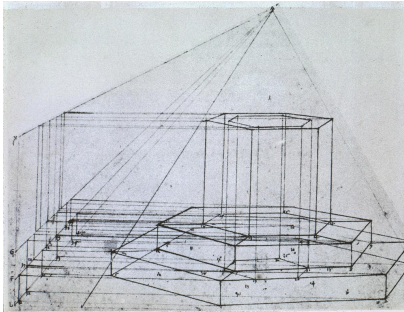

From Piero della Francesca's book *On Perspective for Painting*, c. 1475



Piero della Francesca, 1473



Piero della Francesca, 1473



Leonardo da Vinci



Study for *The Adoration of the Magi*



The Adoration of the Magi, c. 1481



Hans Holbein the Younger, *The Ambassadors*, 1533



Hans Holbein the Younger, *The Ambassadors*, 1533



Hans Holbein the Younger, *The Ambassadors*, 1533



Hans Holbein the Younger, *The Ambassadors*, 1533



David Hockney, acrylic on canvas, 1970



David Hockney, etching and aquatint, 1974

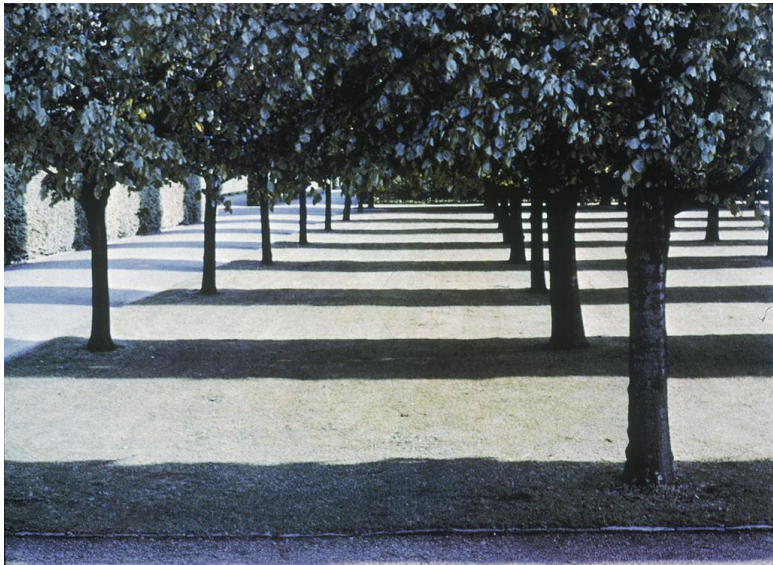

David Hockney



David Hockney, acrylic on canvas

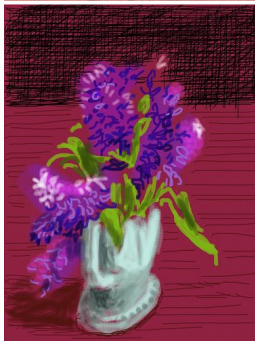
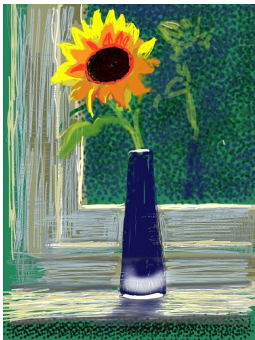
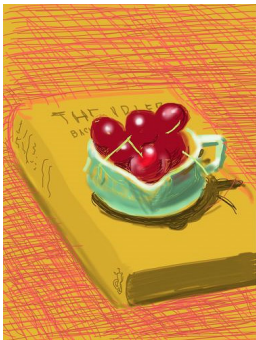

David Hockney, iPad paintings, 2013



David Hockney, acrylic on canvas, 1971



David Hockney, acrylic on canvas, 1971



Hans Holbein the Younger, *The Ambassadors*, 1533

Optics of Spherical Mirrors

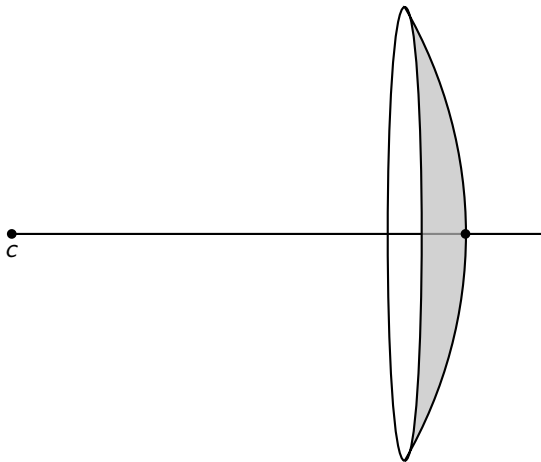

Optics of Spherical Mirrors

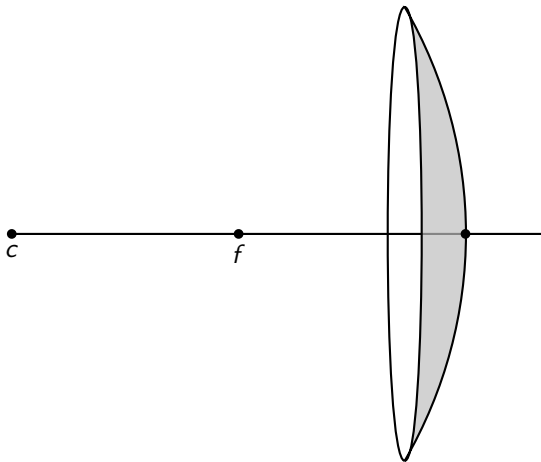

Optics of Spherical Mirrors

P
•

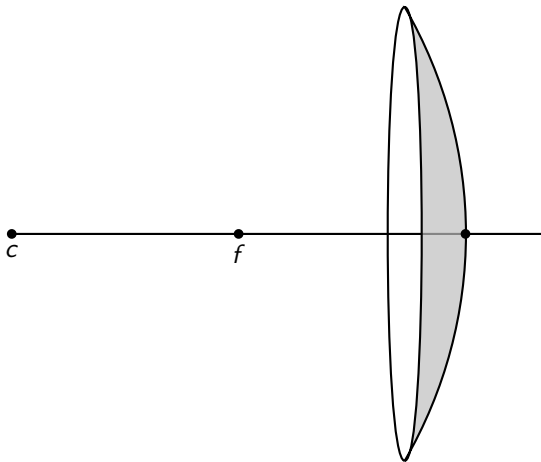

Optics of Spherical Mirrors

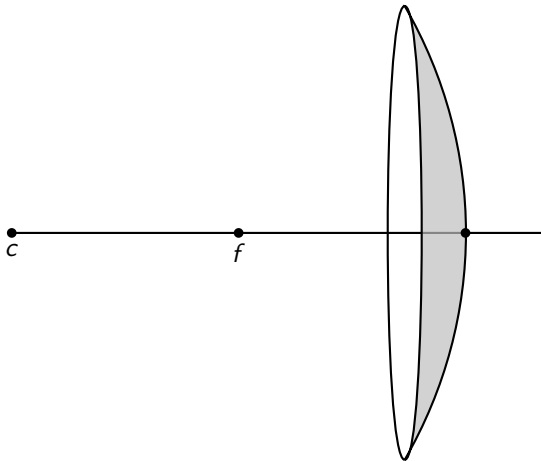

Optics of Spherical Mirrors

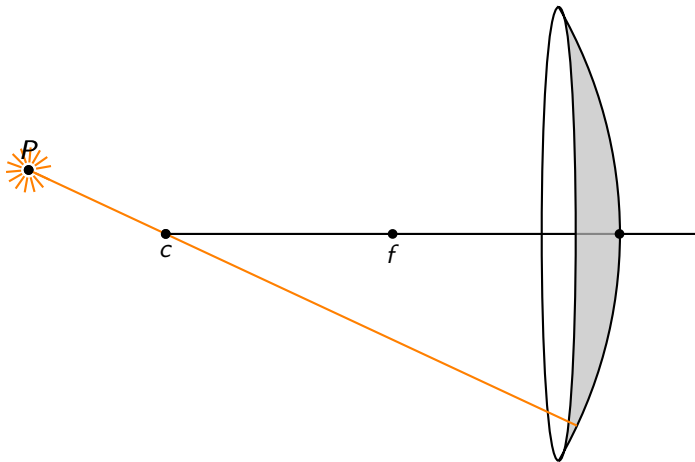

Optics of Spherical Mirrors

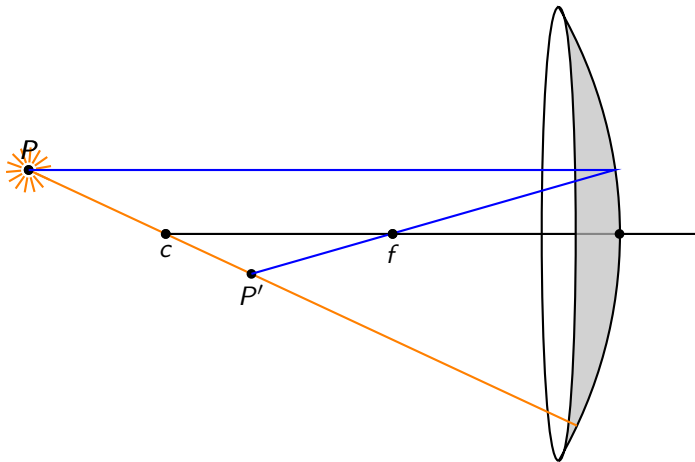

Optics of Spherical Mirrors

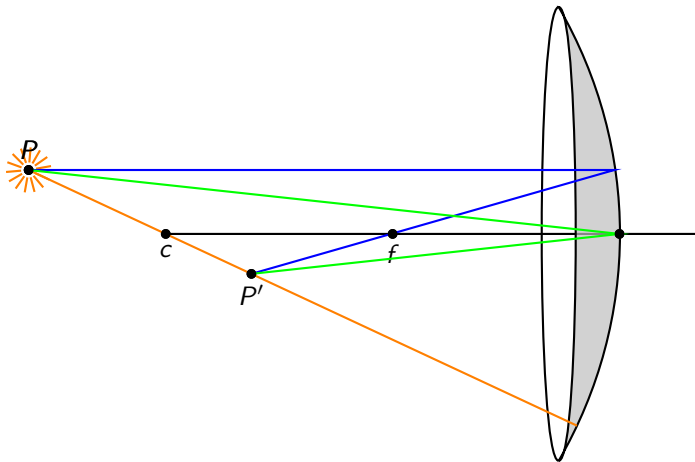

Optics of Spherical Mirrors

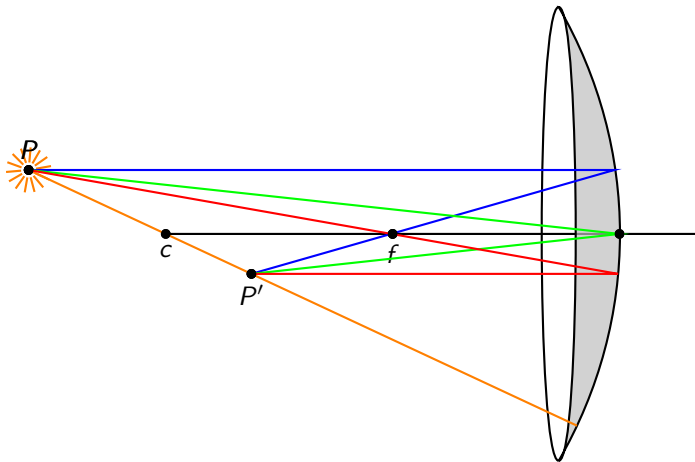

Optics of Spherical Mirrors

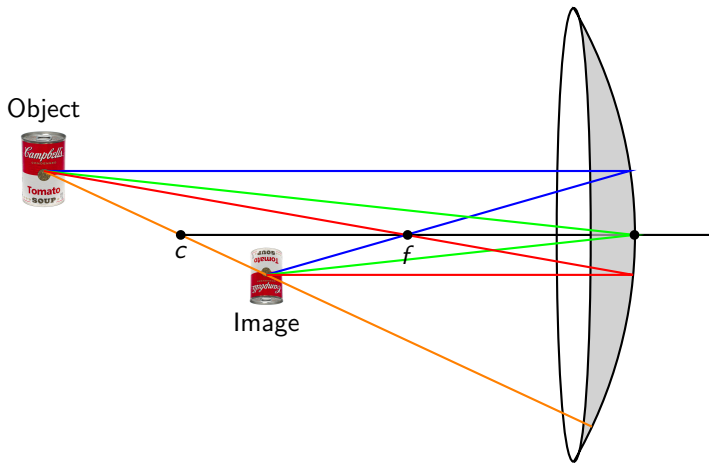

Hockney's Camera Obscura



Hockney's Camera Obscura



Hockney's Camera Obscura

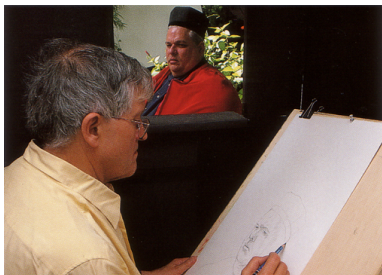



Hans Holbein the Younger, *The Ambassadors*, 1533

Camera Obscura with a Lens

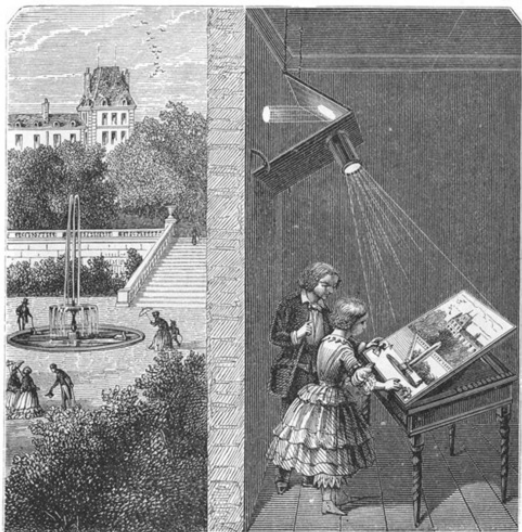



Caravaggio, *The Calling of St. Matthew*, c. 1600

Focusing Shifts the Image



Focusing Shifts the Image





Hans Memling, (Flemish), c. 1480

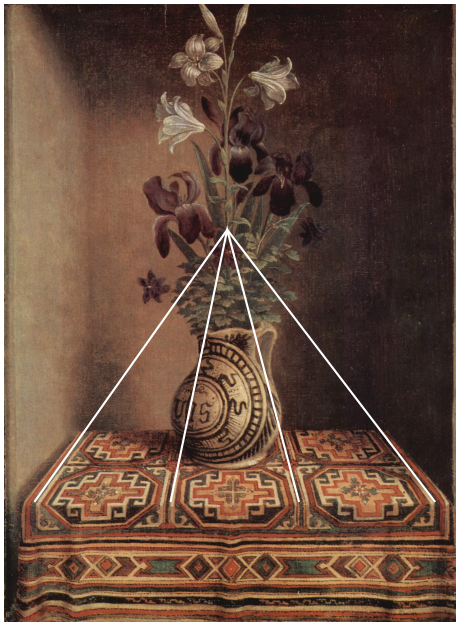

Hans Memling, (Flemish), c. 1480



Hans Memling, (Flemish), c. 1480



Hans Memling, (Flemish), c. 1480



Lorenzo Lotto, c. 1523

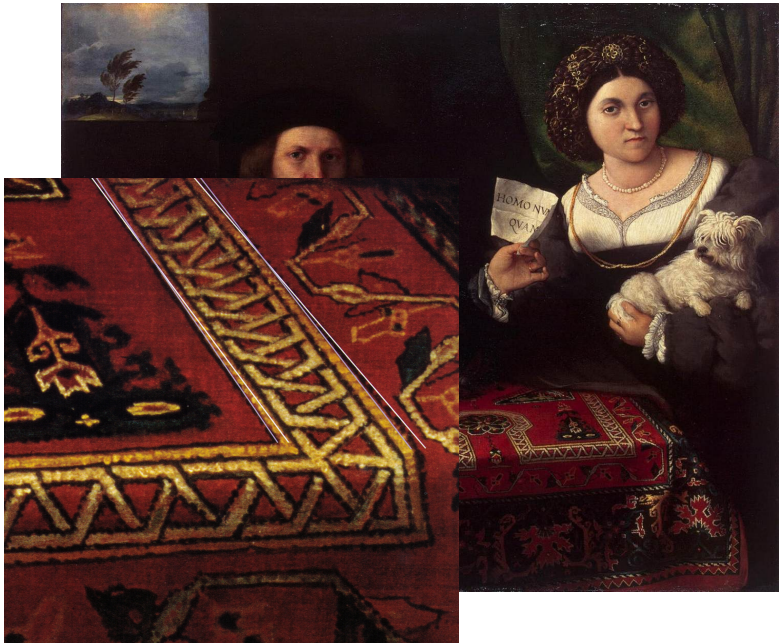

Lorenzo Lotto, c. 1523

Thank You