

MATH 121
(Day 3)

Alberti's Method of Perspective

Richard Hammack:

www.people.vcu.edu/~rhammack/Math121/



Filippo Lippi, c. 1560



Botticelli, 1490



Matteo di Giovanni, Flagellation of Saint Jerome 1476



Giovanni Bellini, c. 1500



Andrea Mantegna, c. 1461



Vittore Carpaccio, c. 1506

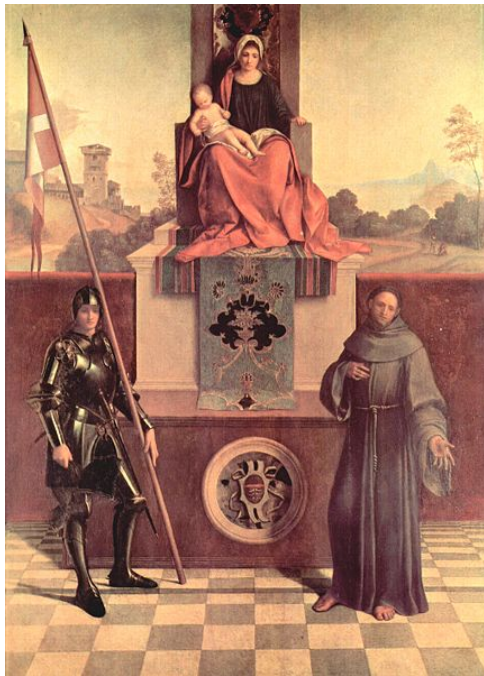

Giorgione, c. 1505



Paolo Uccello, c. 1466

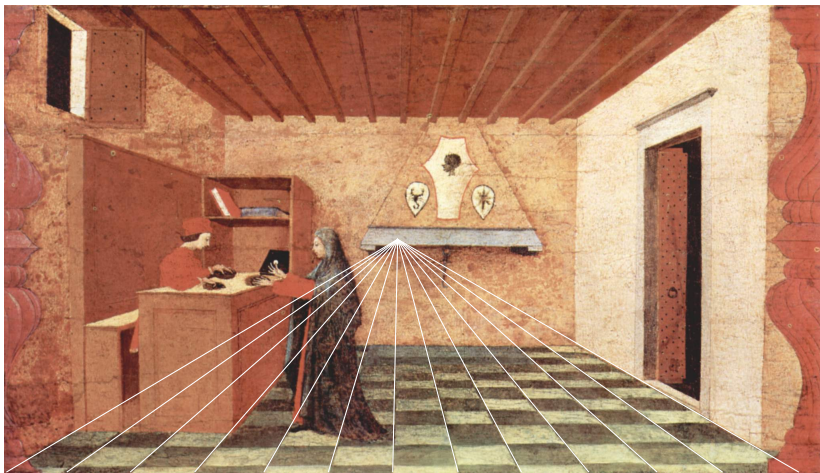

Paolo Uccello, c. 1466

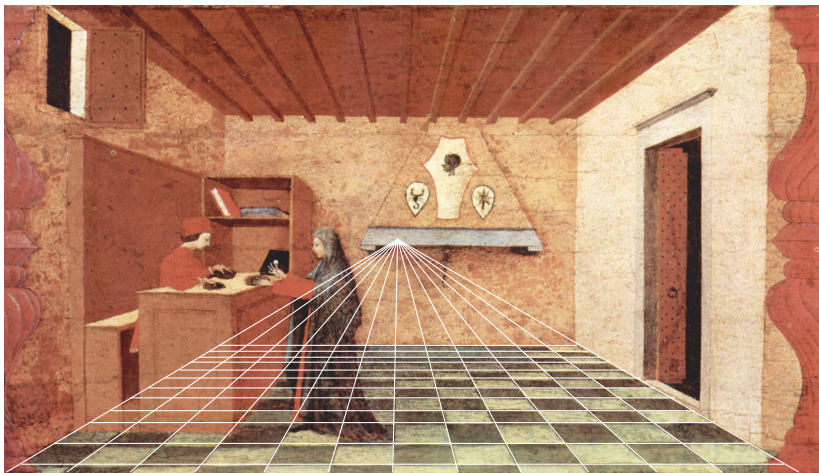

Paolo Uccello, c. 1466

Leone Battista Alberti
1404–1472



Leone Battista Alberti
1404–1472



*"I want the painter, as far as he is able,
to be learned in all the liberal arts, but
I wish him above all to have a good
knowledge of geometry"*

Leone Battista Alberti
1404–1472



"I want the painter, as far as he is able, to be learned in all the liberal arts, but I wish him above all to have a good knowledge of geometry"

"I would especially ask [artists] as a reward for my labors to paint my portrait."

Leone Battista Alberti
1404–1472



"I want the painter, as far as he is able, to be learned in all the liberal arts, but I wish him above all to have a good knowledge of geometry"

"I would especially ask [artists] as a reward for my labors to paint my portrait."

Leone Battista Alberti
1404–1472



"I want the painter, as far as he is able, to be learned in all the liberal arts, but I wish him above all to have a good knowledge of geometry"

"I would especially ask [artists] as a reward for my labors to paint my portrait."



Leone Battista Alberti
1404–1472



"I want the painter, as far as he is able, to be learned in all the liberal arts, but I wish him above all to have a good knowledge of geometry"

"I would especially ask [artists] as a reward for my labors to paint my portrait."



Leone Battista Alberti 1404–1472



"I want the painter, as far as he is able, to be learned in all the liberal arts, but I wish him above all to have a good knowledge of geometry"

"I would especially ask [artists] as a reward for my labors to paint my portrait."



Leone Battista Alberti 1404–1472



"I want the painter, as far as he is able, to be learned in all the liberal arts, but I wish him above all to have a good knowledge of geometry"

"I would especially ask [artists] as a reward for my labors to paint my portrait."



Buildings by Alberti



Santa Maria Novella
Florence, Italy
1456 to 1470



Santa Andrea
Mantua, Italy
1470 to 1476

Books by Alberti

- ▶ *Re Aedificatoria*, 1450
(On the theory and practice of architecture.)
- ▶ *De pictura* (On painting), 1435
(A treatise on perspective in which he describes the mathematics of drawing a tiled floor in correct perspective.)

Books by Alberti

- ▶ *Re Aedificatoria*, 1450
(On the theory and practice of architecture.)
- ▶ *De pictura* (On painting), 1435
(A treatise on perspective in which he describes the mathematics of drawing a tiled floor in correct perspective.)

Today's goal: Learn Alberti's method for drawing a tiled floor in correct perspective

Viewer looks into a room with a **square** floor.

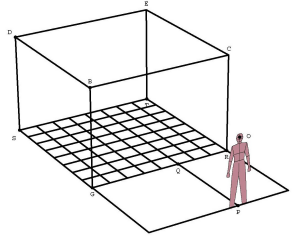

Viewer looks into a room with a **square** floor.
How to draw what the viewer sees:

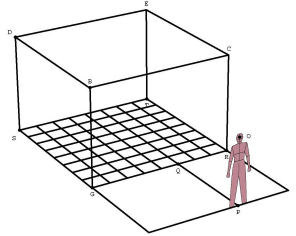

Viewer looks into a room with a **square** floor.
How to draw what the viewer sees:

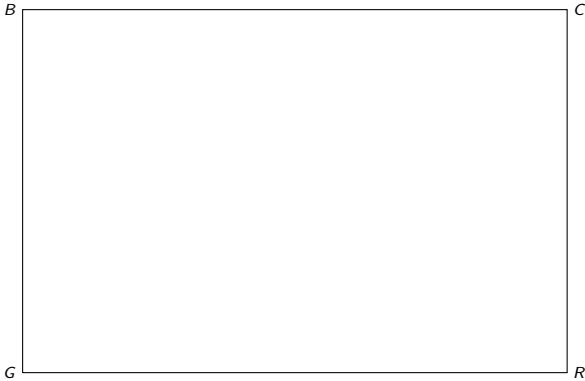
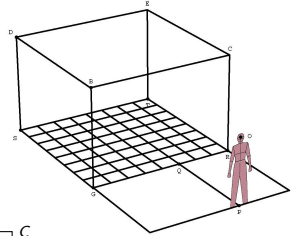

Viewer looks into a room with a **square** floor.
How to draw what the viewer sees:

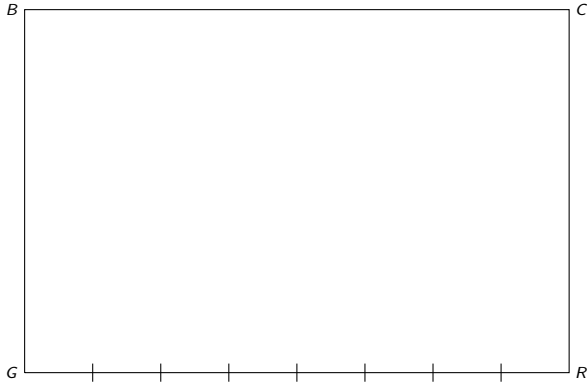
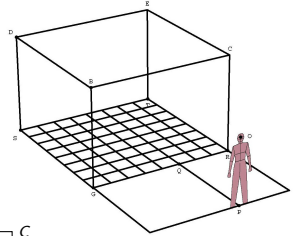

Viewer looks into a room with a **square** floor.
How to draw what the viewer sees:

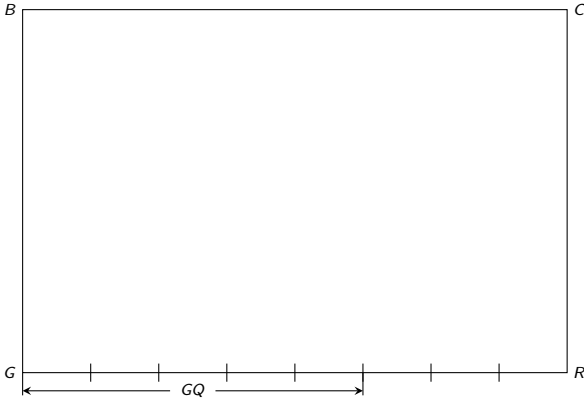
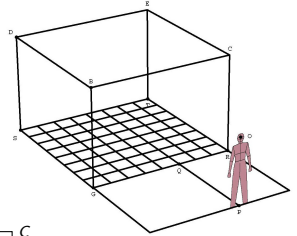

Viewer looks into a room with a **square** floor.
How to draw what the viewer sees:

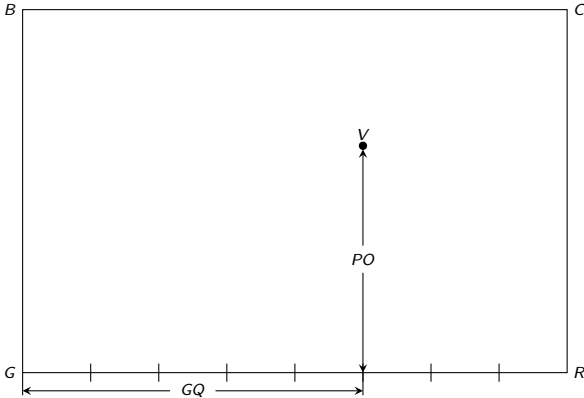
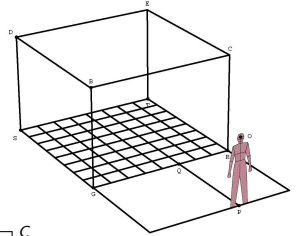

Viewer looks into a room with a **square** floor.
How to draw what the viewer sees:

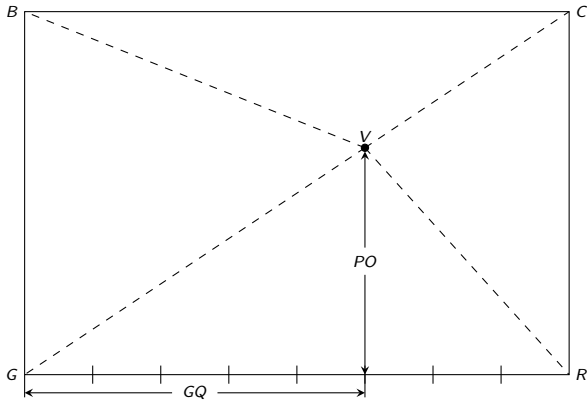
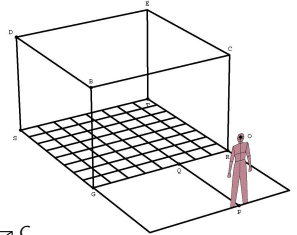

Viewer looks into a room with a **square** floor.
How to draw what the viewer sees:

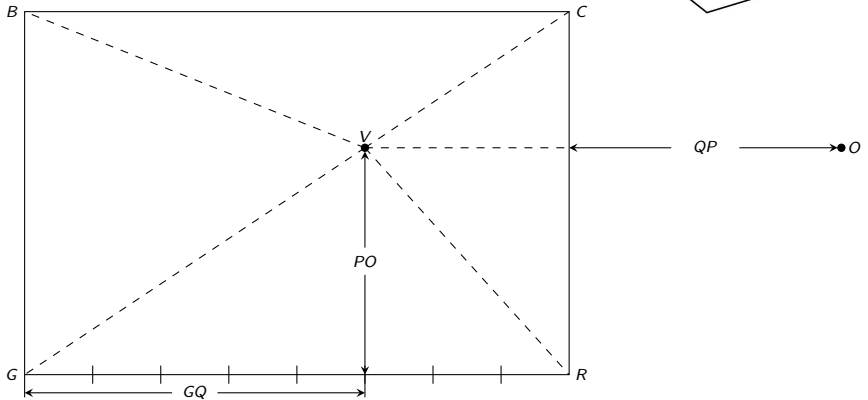
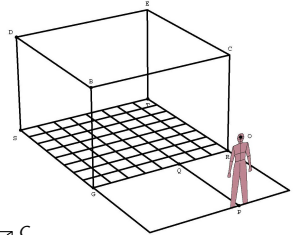

Viewer looks into a room with a **square** floor.
How to draw what the viewer sees:

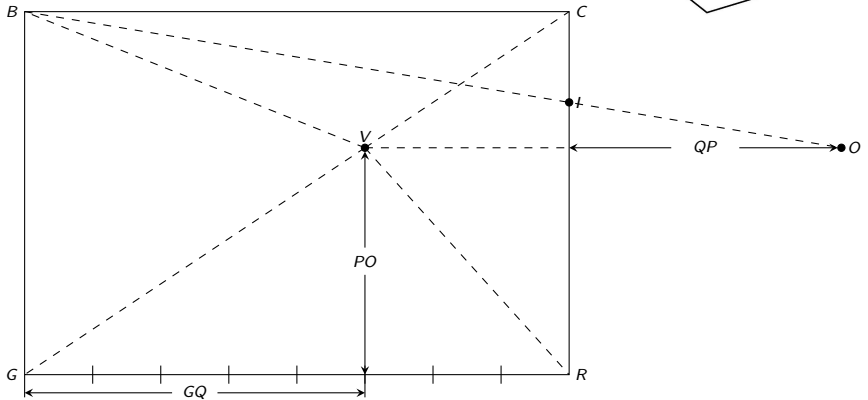
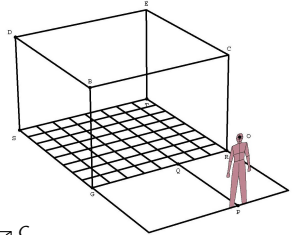

Viewer looks into a room with a **square** floor.
How to draw what the viewer sees:

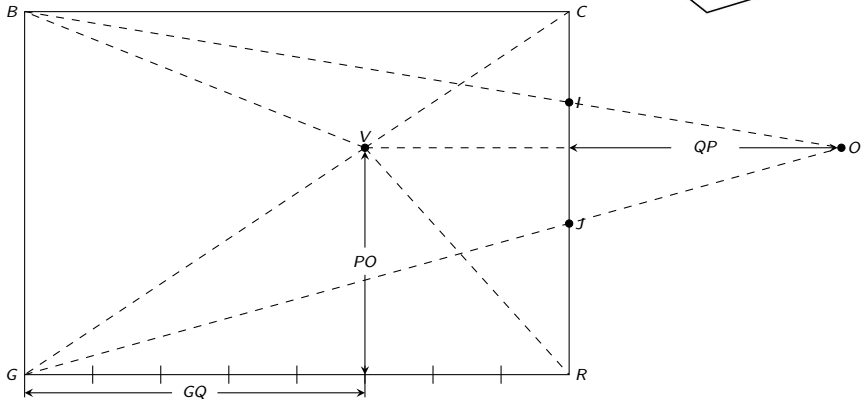
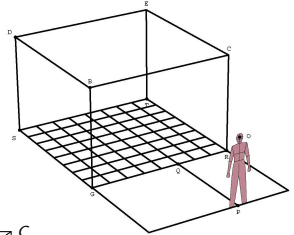

Viewer looks into a room with a **square** floor.
How to draw what the viewer sees:

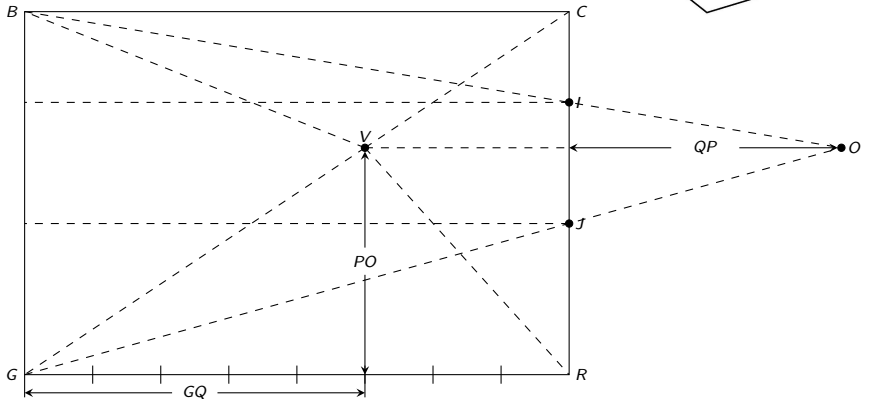
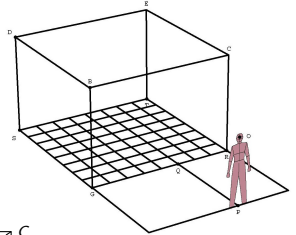

Viewer looks into a room with a **square** floor.
How to draw what the viewer sees:

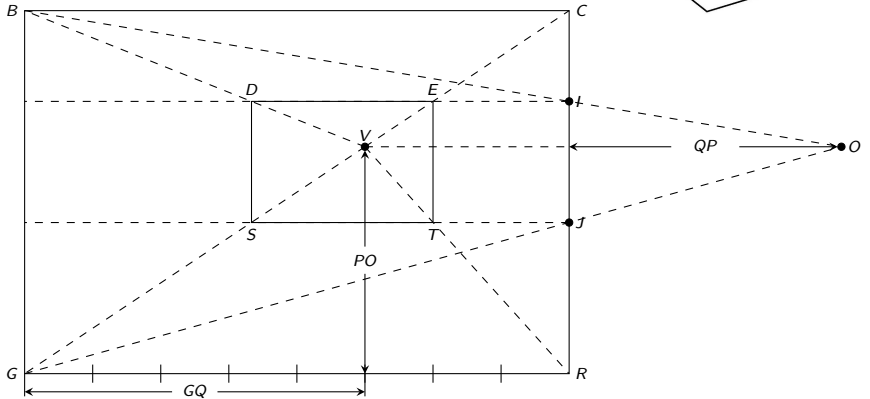
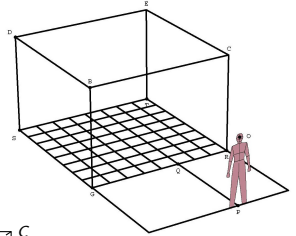

Viewer looks into a room with a **square** floor.
How to draw what the viewer sees:

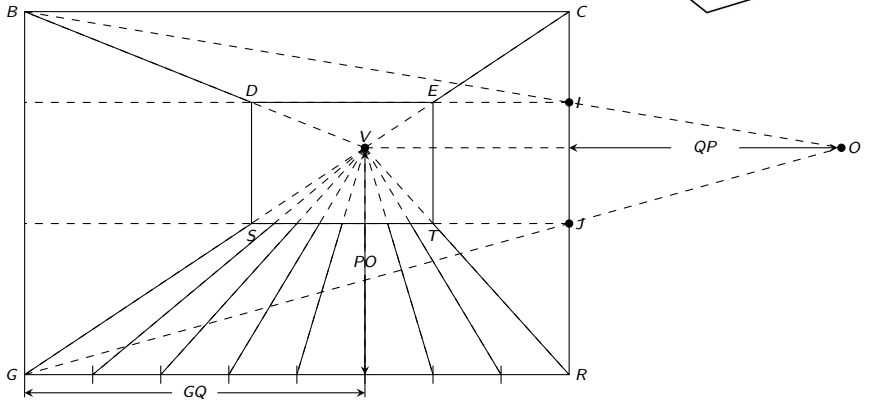
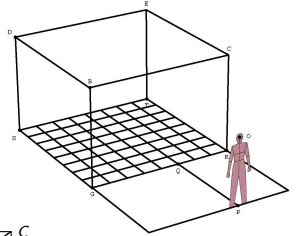

Viewer looks into a room with a **square** floor.
How to draw what the viewer sees:

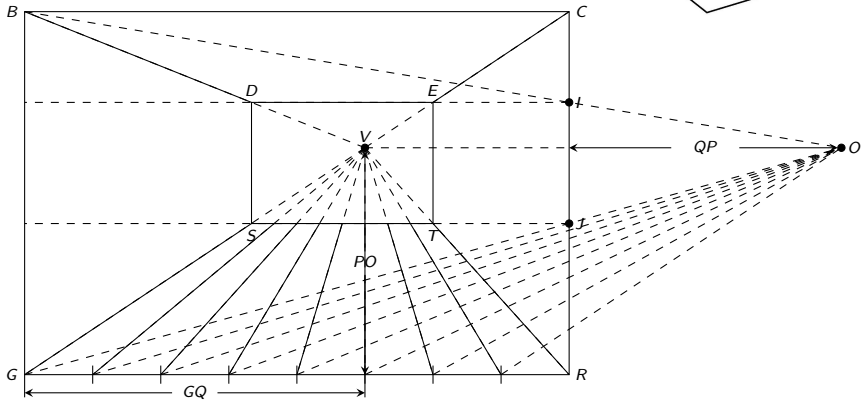
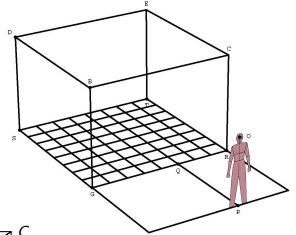

Viewer looks into a room with a **square** floor.
How to draw what the viewer sees:

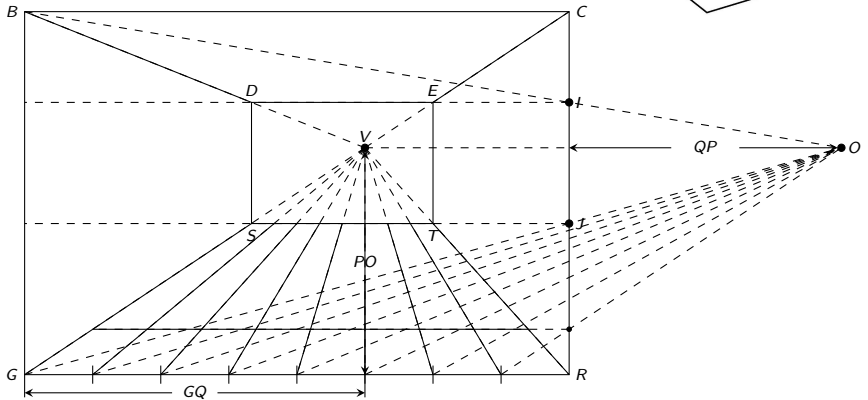
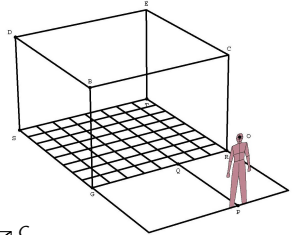

Viewer looks into a room with a **square** floor.
How to draw what the viewer sees:

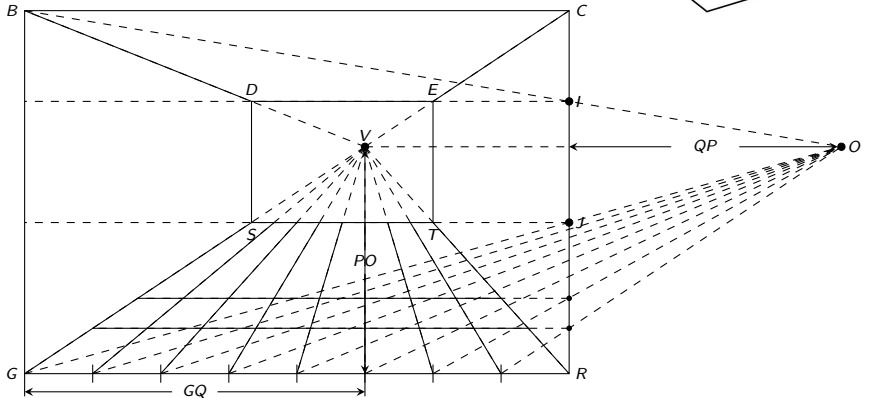
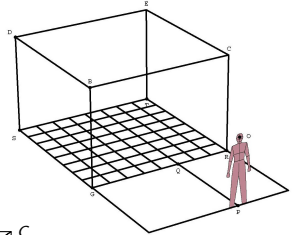

Viewer looks into a room with a **square** floor.
How to draw what the viewer sees:

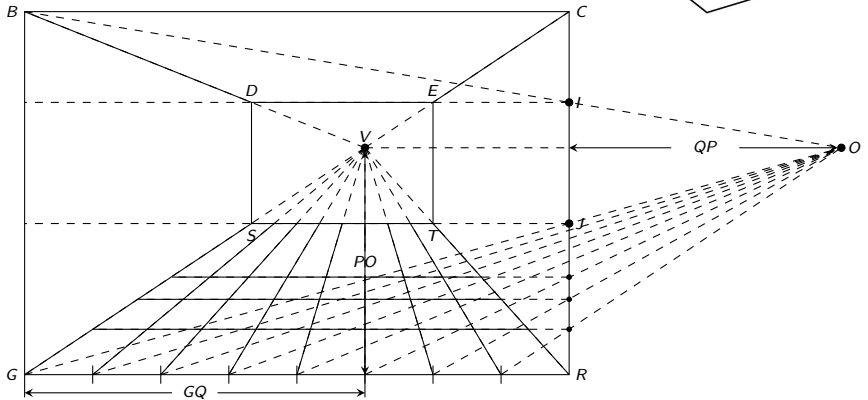
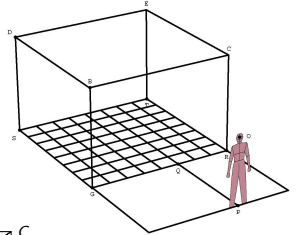

Viewer looks into a room with a **square** floor.
How to draw what the viewer sees:

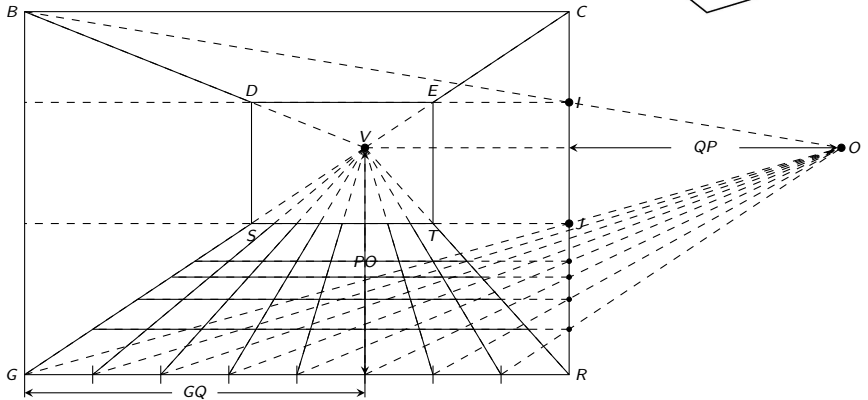
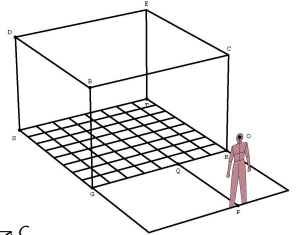

Viewer looks into a room with a **square** floor.
How to draw what the viewer sees:

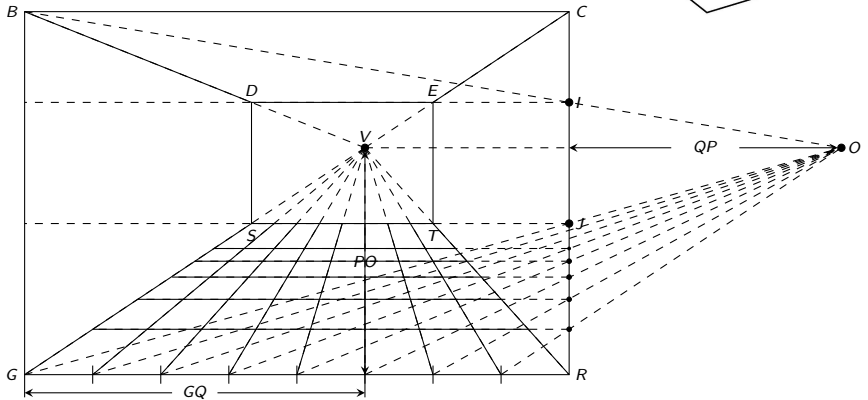
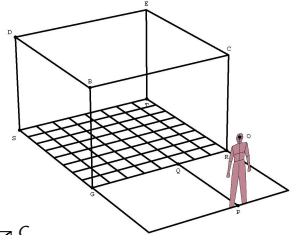

Viewer looks into a room with a **square** floor.
How to draw what the viewer sees:

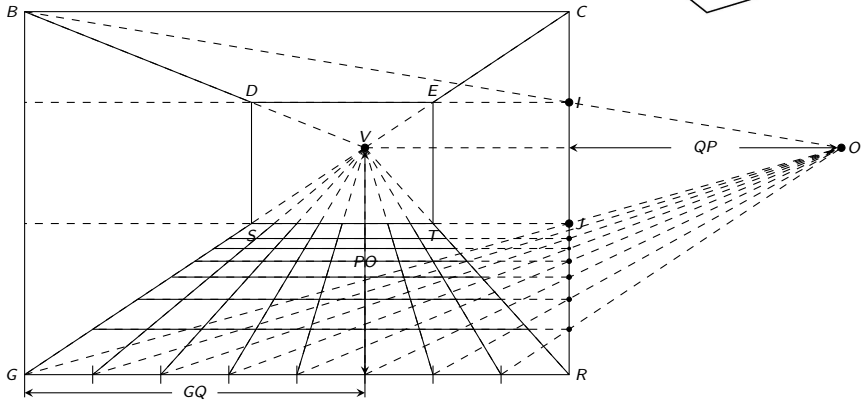
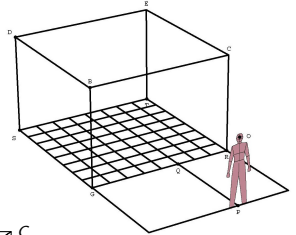

Viewer looks into a room with a **square** floor.
How to draw what the viewer sees:

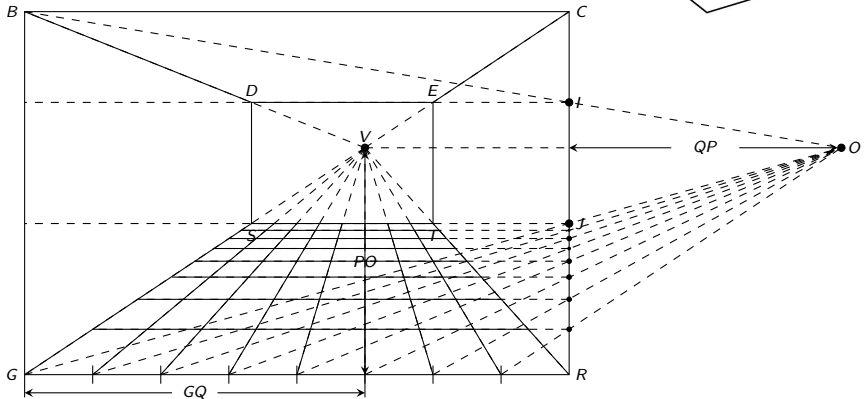
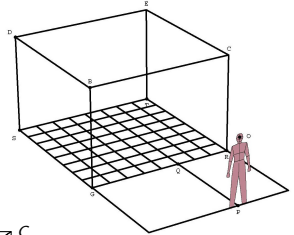

Viewer looks into a room with a **square** floor.
How to draw what the viewer sees:

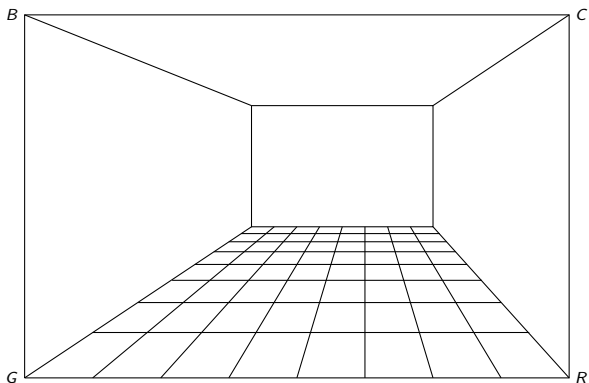
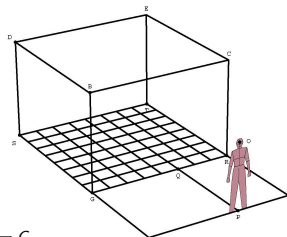

Adaptation to a rectangular floor-plan

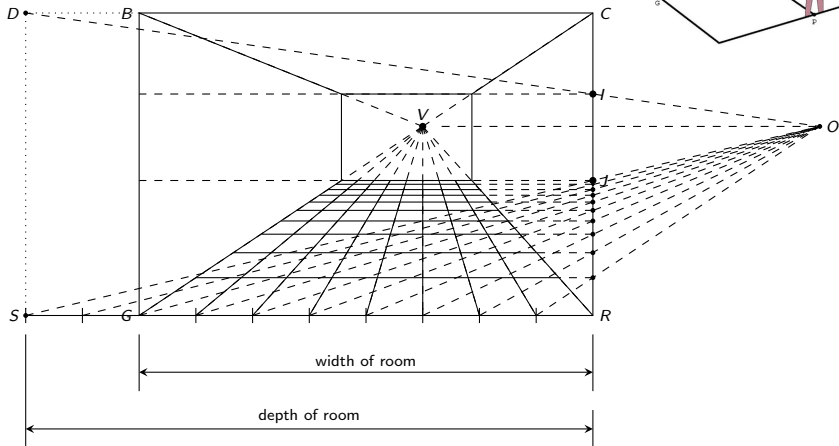
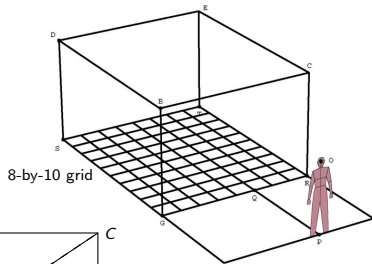

Assignment #2

Drawing what the viewer sees:

